

GRAVITY



Vetrina pasticceria professionale con basamento in tubolare d'acciaio verniciato con polveri epossidiche, predisposizione per ruote (a richiesta) e piedini regolabili. Scocca monoblocco con rivestimento interno interamente in acciaio inox e schiumata con poliuretano iniettato alla densità di 38/40 kg./mc. Piano refrigerato inclinato costituito da pannelli in acciaio inox asportabili. Montanti laterali in plexiglass illuminati a LED. Illuminazione a LED sotto il piano rendi resto e sulle mensole. Vetro anteriore apribile verso il basso, e riscaldato. Vetri laterali stratificati, temprati e riscaldati. N° 3 mensole espositive su H.150 cm., n° 2 mensole espositive su H.137 cm., n° 1 mensola su H. 120 cm., chiusura posteriore con tendina avvolgibile. L'impianto di refrigerazione è ventilato con potenziometro per la regolazione della velocità delle ventole, sbrinamento automatico a fermata, quadro comandi con termostato elettronico, griglia anteriore in alluminio anodizzato argento. Unità condensatrice interna monofase (a richiesta unità condensatrice esterna per distanza da 3 a 10 mt.); vetrina canalizzabile con Gravity gelateria. Evaporazione condensa in automatico su vetrina con motore interno, scarico condensa da collegare alla rete quando la vetrina è con motore esterno. Classe climatica 4 (30° C. - 55% U.R.). Temperatura d'esercizio 0° C. + 5°

Professional pastry shop showcase with tubular epoxy painted steel base and adjustable feet (fitted for wheels, supplied on request). Enbloc body lined throughout in stainless steel, insulated with injected polyurethane, density 38/40 kg/m3. Inclined refrigerated surface consisting of removable stainless steel panels. Side uprights in Plexiglas with integral LED lighting. LED lighting underneath payment surface and on shelves. Heated front glass panel with downward opening. Heated, tempered layered side glass panels. 3 display shelves on H.150 cm, 2 display shelves on H.137 cm, 1 shelf on H. 120 cm, rear enclosed by roller blind. Fan-assisted refrigeration system with potentiometer for fan speed adjustment, automatic defrosting with on-off function, control panel with electronic thermostat, silver anodised aluminium front grille. Integral single-phase condenser unit (remote condenser for installation at a distance of 3 to 10 metres on request); suitable for installation in-line with ice-cream Gravity. Automatic showcase condensate evaporation with integral motor, condensate drain for connection to drainage system when showcase has remote motor. Climate class 4 (30° - R.H. 55%). Operating temperature 0°C + 5° C.



Vetrina gelati professionale con doppia ventilazione. Vetro anteriore apribile verso il basso e riscaldato. Vetri laterali stratificati, temprati e riscaldati. Montanti laterali in plexiglass illuminati a LED. Illuminazione a LED sotto il piano rendi resto. Chiusura posteriore con tendina avvolgibile. Sbrinamento automatico con inversione di ciclo, evaporazione condensa in automatico su vetrine con motore interno, scarico condensa da collegare alla rete quando la vetrina è con motore esterno, griglia anteriore in alluminio anodizzato argento. Unità condensatrici trifase semiermiche su 24-18 vaschette, ermetiche 230V monofase sulla vetrina 12 vaschette. Le unità esterne possono essere dislocate a una distanza massima di 20 m con i compressori semiermiche e metri 10 con quelli ermetici. Sono utilizzabili vaschette da cm. 36x16,5x12h. (5 lt.) o da cm. 36x25x12/8h. (8/5 lt.) con traversini a passo variabile. Kit vaschette non compreso.

Classe climatica 4+ (35° C - 70% U.R.) con compressori semiermetici, Classe 4 (30° - 55% U.R.) con compressori ermetici. Temperatura di esercizio -12°/- 18° C.

Professional ice-cream showcase with dual flow fan-assisted refrigeration. Heated front glass panel with downward opening. Heated, tempered layered side glass panels. Side uprights in Plexiglas with integral LED lighting. LED lighting underneath payment surface. Back enclosed by roller blinds. Automatic reverse cycle defrosting, showcase demister with integral motor, condensate drain for connection to drainage system when showcase has remote motor, silver anodised aluminium front grille. Condenser units, three-phase semi-hermetic on 24-18 tub showcase, hermetic 230V single-phase on 12 tub showcase. Remote units can be located up to 20 m away with semi-hermetic and 10 m with hermetic compressors. To take tubs of 36x16.5x12h cm (5 lt.) or 36x25x12/8h cm (8/5 lt.) with position-adjustable cross-bars. Set of tubs not included. Climate class 4+ (35° C - R.H. 70%) with semi-hermetic compressors, Class 4 (30° - R.H. 55%) with hermetic compressors. Operating temperature -12°/- 18° C.

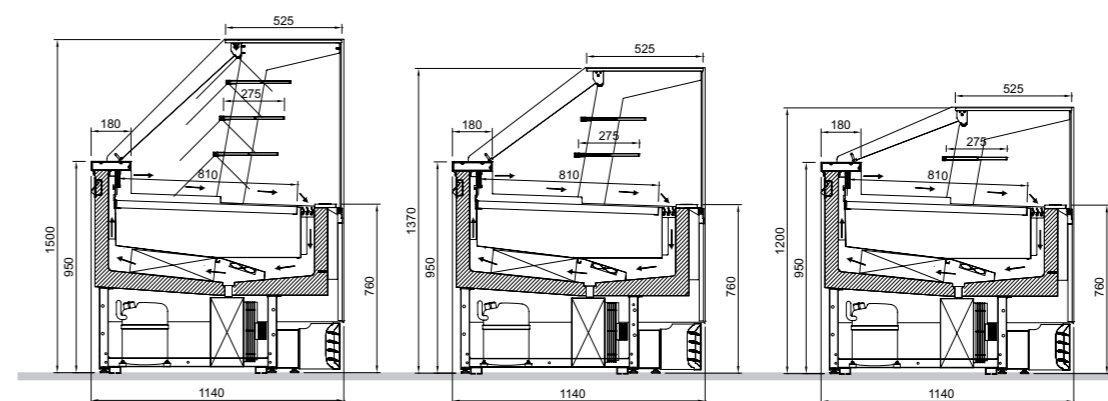

GRAVITY PASTICCERIA / PASTRY
H cm. 120/137/150
L senza fianchi/without side panels: cm. 115/165/215
L con fianchi/with side panels: cm. 123/173/223

Struttura: acciaio inox e alluminio anodizzato
Vetri laterali: stratificati, temprati e riscaldati
Vetro frontale: temprato e riscaldato
Fianchi: laccati RAL /cartella colori a catalogo
Illuminazione piani: LED alta luminosità
Motori: interni o remoti

Structure: stainless steel and anodised aluminium
Side glasses: laminated, tempered and heated
Front glass: tempered and heated
Front panel: lacquered in RAL /catalogue colours
Side panels: lacquered in RAL /catalogue colours
Shelf lighting: high-luminosity LEDs
Motors: integral or remote

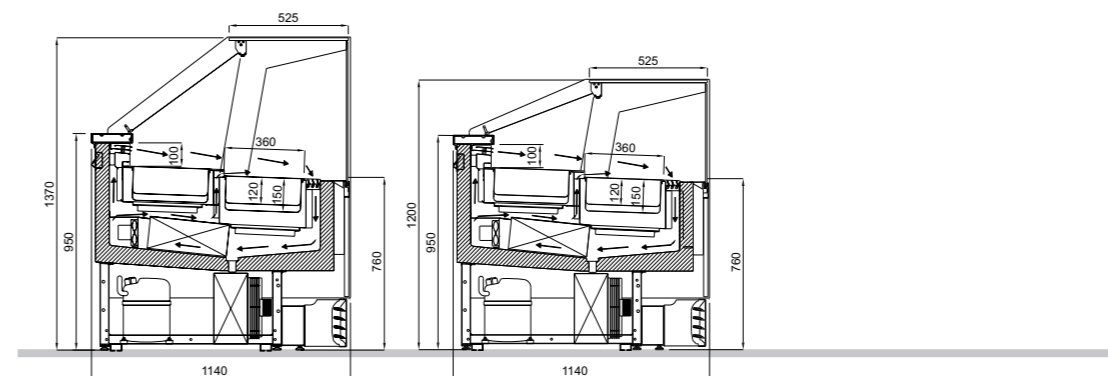

GRAVITY GELATERIA / ICE CREAM
H cm. 120/137
L senza fianchi/without side panels: cm. 115/165/215
L con fianchi/with side panels: cm. 123/173/223

Struttura: acciaio inox e alluminio anodizzato
Vetri laterali: stratificati, temprati e riscaldati
Vetro frontale: temprato e riscaldato
Fianchi: laccati RAL /cartella colori a catalogo
Illuminazione piani: LED alta luminosità
Motori: interni o remoti

Structure: stainless steel and anodised aluminium
Side glasses: laminated, tempered and heated
Front glass: tempered and heated
Front panel: lacquered in RAL /catalogue colours
Side panels: lacquered in RAL /catalogue colours
Shelf lighting: high-luminosity LEDs
Motors: integral or remote



GRAVITY





GRAVITY

LA TRASPARENZA ELEGANTE
DEL CASTELLO VETRI,
PERMETTE UNA VISIONE
COMPLETA E AVVOLGENTE
DEI PRODOTTI.
COLORI E DETTAGLI UNICI
MOSTRATI AL MEGLIO.

THE ELEGANT TRASPARENCE
OF THE GLASS FRAMES,
ENABLES A COMPLETE
AND CAPTIVATING VISION
OF THE PRODUCTS.
UNIQUE COLOURS AND DETAILS
SHOWN AT THEIR BEST.



H150



H137



H120